

# Buckingham Manufacturing BODY BELT SIZING CHART



1. Determine your 'Y' measurement (see method & diagram below).
2. Determine what class your Body Belt is in using the chart below (ex. A 2000M belt is in Class 1).
3. Find your 'Y' measurement, then go across to the column that has your Belt Class. This is the D-size you need to order.  
(ex. Your 'Y' measurement is 24" and you want a Class 1 (2000M) Body Belt, you would order a size 26).

<b>Class 1</b>	2000M, 2000EM*, 20003M, 20005M, 20006M, 2100M, 20182M, 2107M, 1988M, 1958, 1962M, 19655M, 1902, 1993F, 1994F, 1994FR, 4200, 20192M, 20193M, 20122M, 4300
<b>Class 2</b>	2012M, 2013M, 2014M*, 2015M*, 2017M*, 2018M, 20181M, 2019M, 20191M

\*Made in sizes 20-30 only

	Y Measurement	SIZE TO ORDER	
		Class 1	Class 2
Tape Measurement / Sizing Belt Measurement	16	18	20
	17	19	21
	18	20	22
	19	21	23
	20	22	24
	21	23	25
	22	24	26
	23	25	27
	24	26	28
	25	27	29
	26	28	30
	27	29	31
	28	30	32
	29	31	33
	30	32	34
	31	33	35
	32	34	36
	33	35	37
34 (MAX)	36	38	

**X** - Distance from waist to top of hip bone where body belt is typically worn.  
**Y** - Measurement is from front of hip bone, around the back and to the front of the other hip bone (Typically from seam to seam of pants).

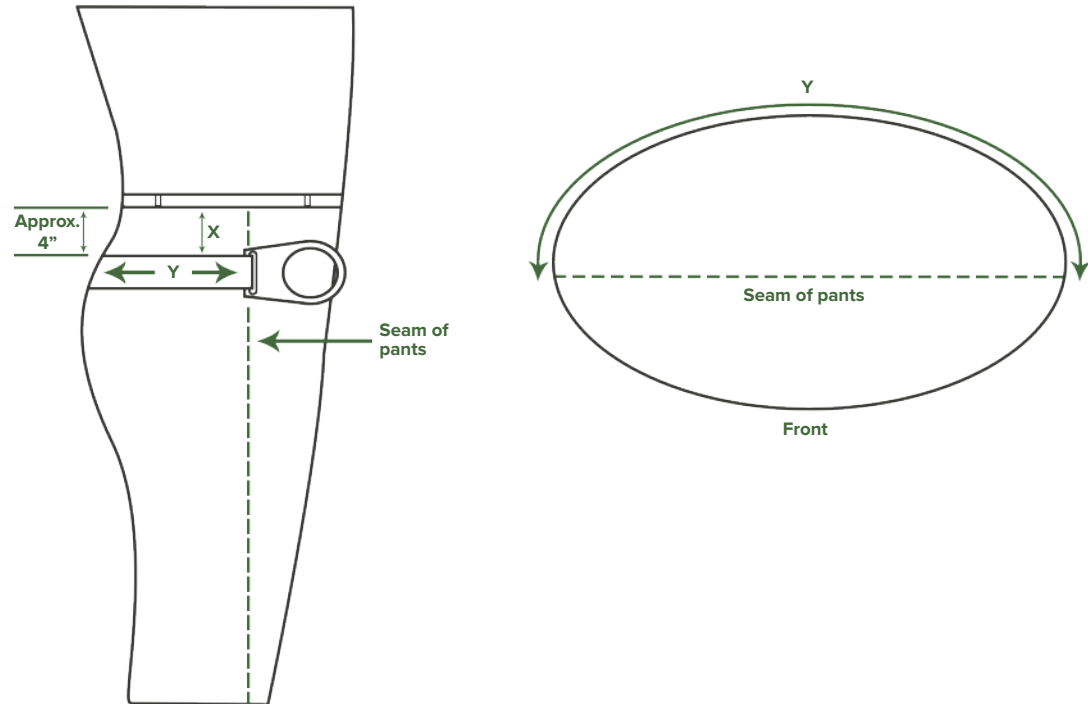

**Note:** To ensure proper body belt sizing, always take your Dee (Y) measurement using a tape or sizing belt. Never rely on you current body belt Dee size.

Green Numbers = Standard Sizes  
 Red Numbers = Non Standard Sizes